

Overview

*A Lithium ion battery must include a safety unit(SU). Also for safety reasons cells are not sold individually.

Dedicated to support various types of mobile equipment with its high-energy density

Lithium Ion Batteries



■ Overview

The battery is a rechargeable battery best suited to mobile devices that require small-size, light weight and high performance. Its characteristics of high energy and high voltage (3.6V) powerfully fulfill these three key requirements. Its standard battery-pack, coupled with a charger, facilitates simple equipment design.

■ Characteristics

1. Less self-discharge (approx. 1/10) compared with a Ni-MH or Ni-Cd batteries as well as no memory effect.
2. A newly developed NNP* series is achieving both high capacity & safety by the use of new positive electrode & high reliable technology by the present charging system (4.2V)
* NNP = Nickel oxide based New Platform
3. The PSS* series adopts nickel and the manganese in new positive electrode.
The safety of a battery to heat improved further.
* PSS = Panasonic Solid Solution

■ Structure

A lithium-ion rechargeable battery consists of a spiral structure with 4 layers. A positive electrode activated by cobalt acid lithium, a negative electrode activated by special carbon, and separator are put together in a whirl pattern and stored in the case. It also incorporates a variety of safety protection systems such as a gas discharge valve which helps prevent the battery from exploding by releasing internal gas pressure if it exceeds the design limit.

■ Safety

Our lithium ion batteries have acquired UL1642. Contact us for further details.

■ Applications

Cellular phone, Note PC etc.

DVC/DSC/DVD/Portable LCD TV etc.

Portable CD player, MD player, Semiconductor-driven audio etc.

Structure of Lithium Ion Batteries (prismatic)

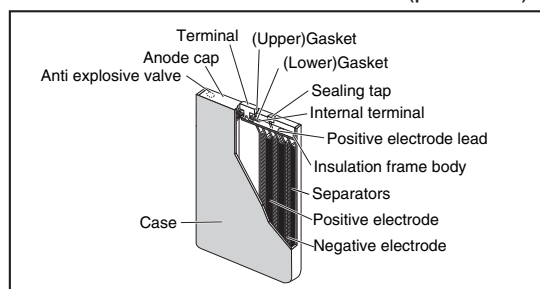

Structure of Lithium Ion Batteries (cylindrical)

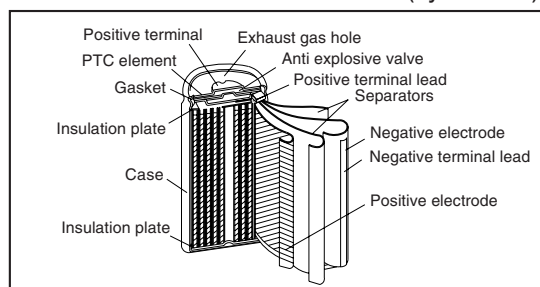

● **Battery Reaction**

The lithium ion battery makes use of lithium cobalt oxide (which has superior cycling properties at high voltages) as the positive electrode and a highly-crystallized specialty carbon as the negative electrode. It uses an organic solvent, optimized for the specialty carbon, as the electrolytic fluid.

The chemical reactions for charge and discharge are as shown below:

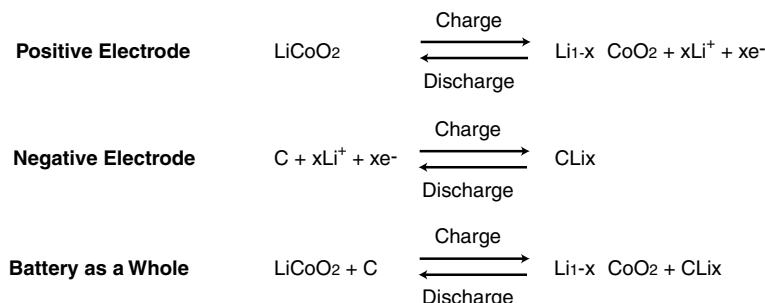

The principle behind the chemical reaction in the lithium ion battery is one where the lithium in the positive electrode lithium cobalt oxide material is ionized during charge, and moves from layer to layer in the negative electrode. During discharge, the ions move to the positive electrode and return to the original compound.

Schematic Diagram of the Chemical Reaction of the Lithium Ion Battery

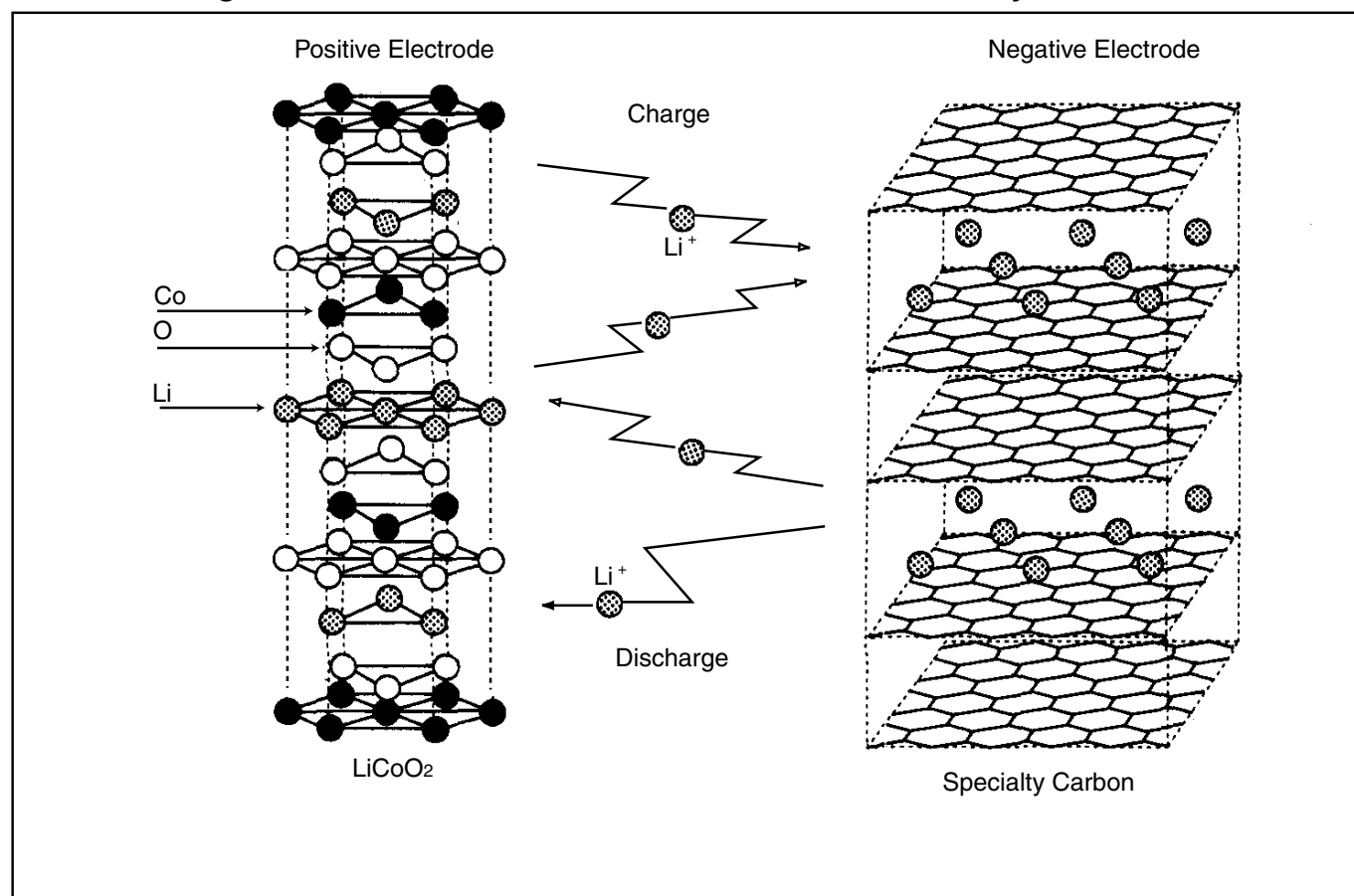

Features

● High Energy Density

Because the lithium ion batteries are high voltage/light weight batteries, they boast a higher energy density than nickel metal hydride (Ni-MH) batteries or nickel cadmium (Ni-Cd) batteries.

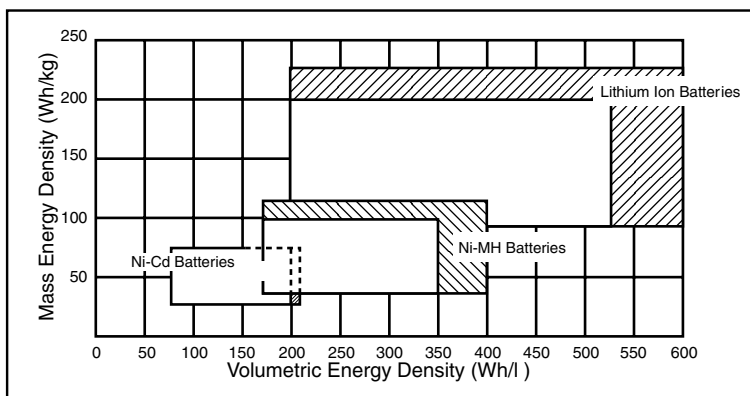

● High Voltage

Lithium ion batteries produce 3.6 volts, approximately three times the voltage of Ni-MH batteries or Ni-Cd batteries. This will make it possible to make smaller, lighter equipment.

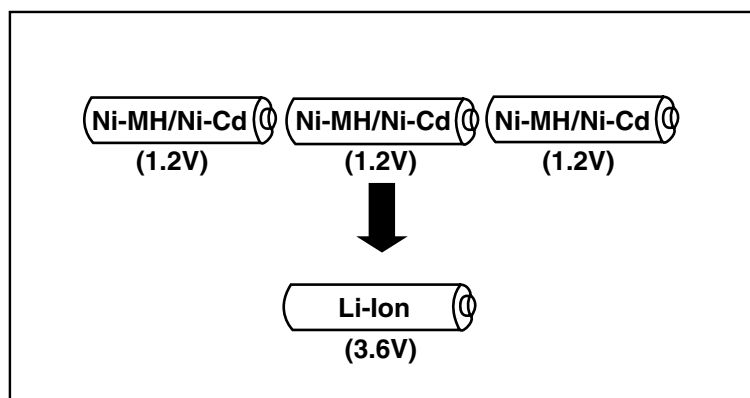

● No Memory Effect

Lithium ion batteries have none of the memory effects seen in Ni-Cd batteries ("memory effect" refers to the phenomenon where the apparent discharge capacity of a battery is reduced when it is repetitively discharged incompletely and then recharged).

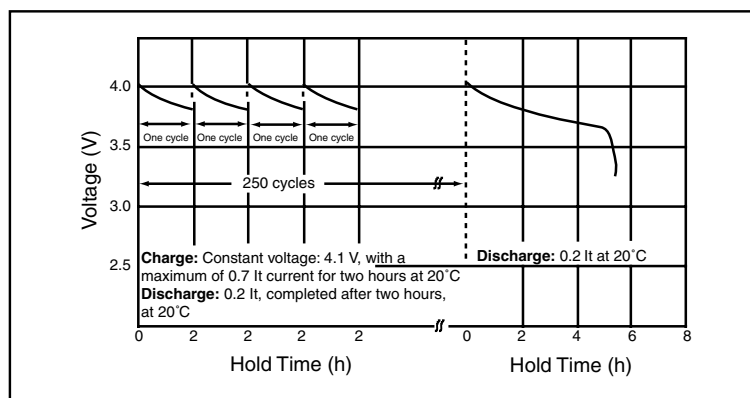

● Flat Discharge Voltage

The use of the specialty carbon creates an extremely flat discharge voltage profile, allowing the production of stable power throughout the discharge period of the battery.

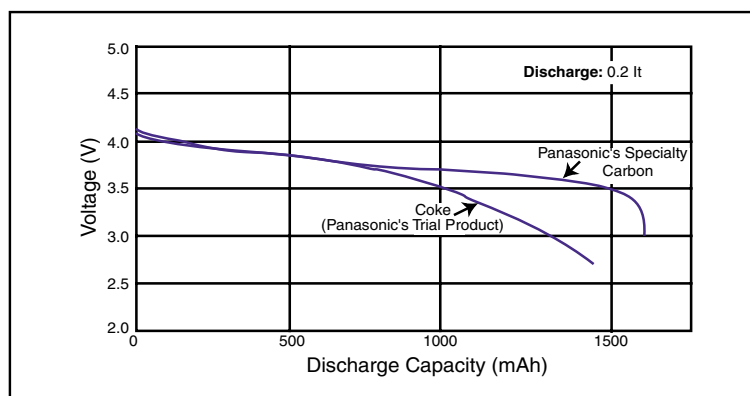

*The data in this document are for descriptive purposes only and are not intended to make or imply any guarantee or warranty.