

ITEM CODE	RATED VOLTAGE	CAP. μ F (*)	DIMENSIONS							MARKING STYLE
			L	T	H	F	G	d		
ECQE2103 () TZ	250VDC	0.01 (103)	10.8	4.3	7.4	7.5	1.0	0.6	1	
" 2123 () TZ	"	0.012 (123)	"	4.4	7.5	"	"	"	"	
" 2153 () TZ	"	0.015 (153)	"	"	"	"	"	"	"	
" 2183 () TZ	"	0.018 (183)	"	"	"	"	"	"	"	
" 2223 () TZ	"	0.022 (223)	"	"	"	"	"	"	"	
" 2273 () TZ	"	0.027 (273)	"	"	"	"	"	"	"	
" 2333 () TZ	"	0.033 (333)	"	4.5	"	"	"	"	"	
" 2393 () TZ	"	0.039 (393)	"	"	"	"	"	"	"	
" 2473 () TZ	"	0.047 (473)	"	"	"	"	"	"	"	
" 2563 () TZ	"	0.056 (563)	"	4.8	7.9	"	"	"	"	
" 2683 () TZ	"	0.068 (683)	"	4.5	7.5	"	"	"	"	
" 2823 () TZ	"	0.082 (823)	"	4.9	8.0	"	"	"	"	
" 2104 () TZ	"	0.1 (104)	"	5.8	8.4	"	"	"	"	
" 2124 () TZ	"	0.12 (124)	"	6.0	9.0	"	"	"	"	
" 2154 () TZ	"	0.15 (154)	"	"	10.8	"	"	"	"	
" 2184 () TZ	"	0.18 (184)	12.5	5.0	10.3	10.0	"	"	"	
" 2224 () TZ	"	0.22 (224)	"	5.5	10.5	"	"	"	"	
" 2274 () TZ	"	0.27 (274)	"	6.0	11.5	"	"	"	"	
" 2334 () TZ	"	0.33 (334)	"	6.5	12.0	"	"	"	"	
" 2394 () TZ	"	0.39 (394)	19.0	4.9	"	15.0	"	"	2	
" 2474 () TZ	"	0.47 (474)	"	5.3	12.5	"	"	"	"	
" 2564 () TZ	"	0.56 (564)	"	5.5	13.0	"	"	"	"	
" 2684 () TZ	"	0.68 (684)	"	6.0	13.5	"	"	0.8	"	
" 2824 () TZ	"	0.82 (824)	"	6.5	14.5	"	"	"	"	
" 2105 () TZ	"	1.0 (105)	"	7.4	15.0	"	"	"	"	
" 2125 () TZ	"	1.2 (125)	"	8.0	15.9	"	"	"	"	
" 2155 () TZ	"	1.5 (155)	"	9.0	16.8	"	"	"	"	
" 2185 () TZ	"	1.8 (185)	26.5	7.5	15.5	22.5	"	"	"	
" 2225 () TZ	"	2.2 (225)	"	8.5	16.3	"	"	"	"	
" 2275 () TZ	"	2.7 (275)	"	9.4	17.0	"	"	"	"	
" 2335 () TZ	"	3.3 (335)	"	10.3	18.0	"	1.5	"	"	
" 2395 () TZ	"	3.9 (395)	"	11.0	20.5	"	"	"	"	
" 2475 () TZ	"	4.7 (475)	"	12.0	21.5	"	"	"	"	
" 2565 () TZ	"	5.6 (565)	31.5	11.8	21.0	27.5	"	"	"	
" 2685 () TZ	"	6.8 (685)	"	13.0	22.4	"	"	"	"	
" 2825 () TZ	"	8.2 (825)	"	14.3	23.5	"	"	"	"	
" 2106 () TZ	"	10.0 (106)	"	15.9	25.8	"	"	"	"	

TOL. SYMBOL (J or K)

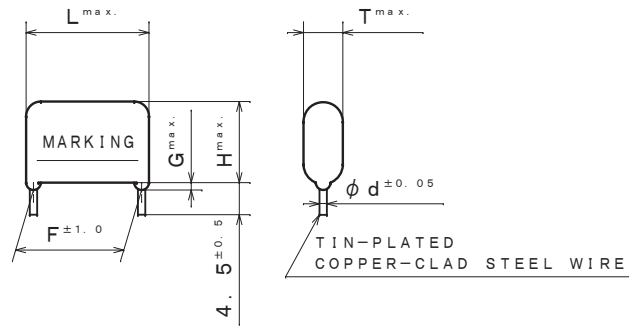

ITEM CODE NUMBER STRUCTURE

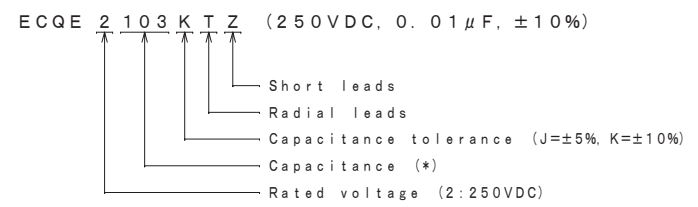

CONSTRUCTION

The capacitor is of non-inductive construction, wound with metallized polyester film dielectric.
The capacitor is enclosed in non-combustible epoxy resin and has two leads.

MARKING

Marking comprises capacitance, capacitance tolerance, rated voltage, manufacturer's trademark (STYLE 2 only) and date code.

PROPERTIES

Capacitance	: See table	at 1kHz
Capacitance tolerance	: ±5% (J), ±10% (K)	at 1kHz
Rated voltage	: 250VDC	(Derating of rated voltage by 1.25%/°C at more than 85°C)
Withstand voltage	: 250VDC×150%	for 60s
Insulation resistance	: ≥9000MΩ	(C≤0.33µF) at 100VDC, 20°C for 60s
	: ≥3000MΩ·µF	(C>0.33µF) at 100VDC, 20°C for 60s
Dissipation factor	: ≤1.0%	at 1kHz, 20°C
Category temperature range	: From -40°C to +105°C	(including temperature rise on unit surface)

MARKING EXAMPLE

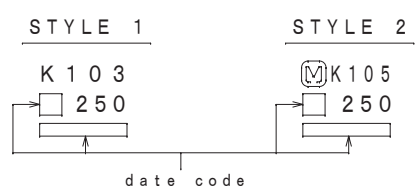

ALTERATION		
ISSUE	DESCRIPTION	DATE
△	Company name changed	Apr. 1 2012
△	Company name changed	Apr. 1 2013
△	Company name changed	Apr. 1 2015
△	Company name changed	Apr. 1 2022

SPECIFICATIONS No.

DESIGN	M. MEKADA
CHECKED	T. KATO
APPROVAL	T. KATO
ESTABLISHMENT	Oct. 4, 2010
TYPE NAME	
ECQE2*** () TZ	
NAME Metallized Polyester Film Capacitor	
DRAWING NAME	
PRODUCT DRAWING	
DRAWING No.	
0031M-J-E (1/1)	

Film Capacitor Business Unit
Device Solutions Business Division
Panasonic Industry Co., Ltd.