

ITEM CODE	CAPACITANCE μF (*)	DIMENSIONS					ITEM CODE	CAPACITANCE μF (*)	DIMENSIONS				
		L	T	H	S	d			L	T	H	S	d
ECWF4223 () LB	0.022 (223)	12.5	5.8	8.6	7.5	0.6	ECWF4244 () LB	0.24 (244)	18.0	8.3	13.0	10.0	0.8
" 4243 () LB	0.024 (243)	"	6.0	8.8	"	"	" 4274 () LB	0.27 (274)	"	8.8	13.4	"	"
" 4273 () LB	0.027 (273)	"	6.2	9.0	"	"	" 4304 () LB	0.3 (304)	"	9.2	13.9	"	"
" 4303 () LB	0.03 (303)	"	6.4	9.3	"	"	" 4334 () LB	0.33 (334)	"	9.6	14.3	"	"
" 4333 () LB	0.033 (333)	"	6.7	9.5	"	"	" 4364 () LB	0.36 (364)	"	9.9	14.7	"	"
" 4363 () LB	0.036 (363)	"	5.7	8.4	"	"	" 4394 () LB	0.39 (394)	"	10.3	15.1	"	"
" 4393 () LB	0.039 (393)	"	5.8	8.6	"	"	" 4434 () LB	0.43 (434)	"	10.7	15.6	"	"
" 4433 () LB	0.043 (433)	"	6.0	8.8	"	"	" 4474 () LB	0.47 (474)	"	11.2	16.1	"	"
" 4473 () LB	0.047 (473)	"	6.2	9.0	"	"	" 4514 () LB	0.51 (514)	20.5	10.3	16.8	12.5	"
" 4513 () LB	0.051 (513)	"	6.4	9.2	"	"	" 4564 () LB	0.56 (564)	"	10.7	17.3	"	"
" 4563 () LB	0.056 (563)	"	6.6	9.4	"	"	" 4624 () LB	0.62 (624)	"	11.3	17.9	"	"
" 4623 () LB	0.062 (623)	13.0	6.8	9.6	"	0.8	" 4684 () LB	0.68 (684)	"	11.8	18.5	"	"
" 4683 () LB	0.068 (683)	"	7.0	9.9	"	"	" 4754 () LB	0.75 (754)	"	12.3	19.1	"	"
" 4753 () LB	0.075 (753)	"	7.3	10.1	"	"	" 4824 () LB	0.82 (824)	23.0	11.8	18.5	"	"
" 4823 () LB	0.082 (823)	"	7.5	10.4	"	"	" 4914 () LB	0.91 (914)	"	12.4	19.2	"	"
" 4913 () LB	0.091 (913)	"	7.8	10.7	"	"	" 4105 () LB	1.0 (105)	"	13.0	19.8	"	"
" 4104 () LB	0.1 (104)	15.5	6.5	11.0	"	"	" 4115 () LB	1.1 (115)	"	13.6	20.5	"	"
" 4114 () LB	0.11 (114)	"	6.8	11.3	"	"	" 4125 () LB	1.2 (125)	28.0	12.3	19.1	17.5	"
" 4124 () LB	0.12 (124)	"	7.0	11.5	"	"	" 4135 () LB	1.3 (135)	"	12.8	19.6	"	"
" 4134 () LB	0.13 (134)	"	7.2	11.8	"	"	" 4155 () LB	1.5 (155)	"	13.7	20.7	"	"
" 4154 () LB	0.15 (154)	"	7.6	12.2	"	"	" 4165 () LB	1.6 (165)	"	14.2	21.2	"	"
" 4164 () LB	0.16 (164)	"	7.8	12.4	"	"	" 4185 () LB	1.8 (185)	"	15.2	22.2	"	"
" 4184 () LB	0.18 (184)	"	8.2	12.8	"	"	" 4205 () LB	2.0 (205)	"	16.0	23.1	"	"
" 4204 () LB	0.2 (204)	"	8.6	13.3	"	"	" 4225 () LB	2.2 (225)	"	16.8	24.0	"	"
" 4224 () LB	0.22 (224)	"	9.0	13.6	"	"	" 4245 () LB	2.4 (245)	"	17.5	24.8	"	"

ALTERATION		
ISSUE	DESCRIPTION	DATE
△	Company name changed	Oct. 1 2004
△	Company name changed	Apr. 1 2005
△	Company name changed	Apr. 1 2006
△	Company name changed	Apr. 1 2008
△	Company name changed	Apr. 1 2012
△	Company name changed	Apr. 1 2013
△	Company name changed	Apr. 1 2015
△	Company name changed	Apr. 1 2022

SPECIFICATIONS No.

ITEM CODE NUMBER STRUCTURE

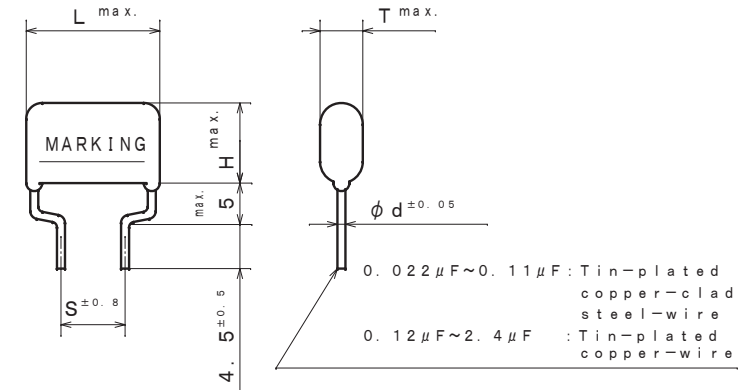
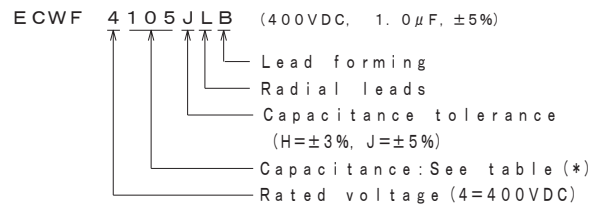

CONSTRUCTION

The capacitor is of non-inductive construction, wound with metallized polypropylene film dielectric.  
 The capacitor is enclosed in non-combustible epoxy resin and has two leads.

MARKING

Marking comprises capacitance, capacitance tolerance, rated voltage, manufacturer's trademark, type name "WFL" and manufacturer's date code.

PROPERTIES

- Capacitance : See table at 1kHz
- Capacitance tolerance : ±3% (H), ±5% (J)
- Rated voltage : 400VDC
- Withstand voltage : Rated voltage × 150% for 60s
- Insulation resistance : C ≤ 0.33μF : ≥ 9,000Ω } at 100VDC, 20°C for 60s  
 : C > 0.33μF : ≥ 3,000Ω·μF
- Dissipation factor : ≤ 0.05% at 1kHz, 20°C
- Category temperature range : From -40°C to +105°C (including temperature rise on unit surface)

(example)

(223~913)	(104, 114)	(124~245)
WFL 223J 400V	WFL 104J 400V	WFL 124J 400V
date code	date code	date code

※The marking of 'WFL' with the underline means that the copper wire is used for the lead wire, while the one without the underline means that tinned copper clad-steel wire is used.

DESIGN	M. MEKADA
CHECKED	H. YAMADA
APPROVAL	T. KATO
ESTABLISHMENT	Feb. 3, 2003
TYPE NAME ECWF 4*** () LB	
NAME METALLIZED POLYPROPYLENE CAPACITOR	
DRAWING NAME PRODUCT DRAWING	
DRAWING No. 3011J-J-E (1/1)	

Film Capacitor Business Unit  
 Device Solutions Business Division  
 Panasonic Industry Co., Ltd.